

Name:

Enrolment No:



**UNIVERSITY OF PETROLEUM AND ENERGY STUDIES**  
**End Semester Examination, May 2019**

**Course: Theory of Machines**  
**Program: B. Tech (Mechanical Engineering)**  
**Course Code: MECH 2006**

**Semester: IV**  
**Time 03 hrs.**  
**Max. Marks: 100**

**Instructions: Note: Attempt all questions, internal choices are given. Section B and Section C, both having ONE INTERNAL choice.**

**Total no. of pages -03**

**SECTION A**

S. No.		Marks	CO
Q 1	Explain with the help of sketches (i) reverted gear train (ii) compound gear train	05	CO3
Q 2	Define Grashof's law. State how is it helpful in classifying the four-link mechanisms into different different types.	05	CO1
Q 3	Explain different types of cams and follower based on shape of the follower, illustrate your answer with the help of sketches.	05	CO2
Q 4	Discuss main tooth profiles of gear teeth, which fulfil the law of gearing. Compare them.	05	CO3

**SECTION B**

Q 5	In case of cam and follower arrangement. Deduce expressions for the velocity and acceleration of the follower when it moves with simple harmonic motion (SHM).	10	CO2
Q 6	Explain path of contact of involute gearing. Derive the relation for its magnitude.	10	CO3
Q 7	Locate all the Instantaneous centre for the mechanism shown in Fig. 1. given below determines the angular velocities of links 2 and 3 for 150 rpm of link4.	10	CO1

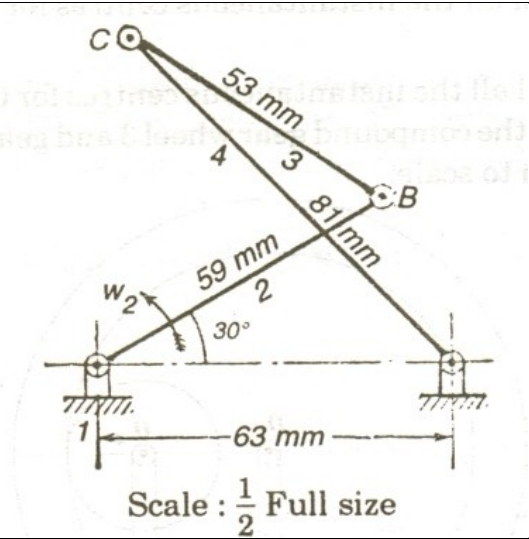

**Fig. 1**

Q 8 An epicyclic train is shown in Fig. 2. It comprises a fixed annular wheel A having 150 teeth. Wheel B meshes with wheel A and drives wheel D through an idler C. The wheel A and D are concentric. Arm F carries wheels B and C and rotates clockwise about the axis of A or D. If the wheels B and D have 25 and 40 teeth respectively, determine the number of teeth on C and its speed and direction of rotation, and the speed of gear wheel D.

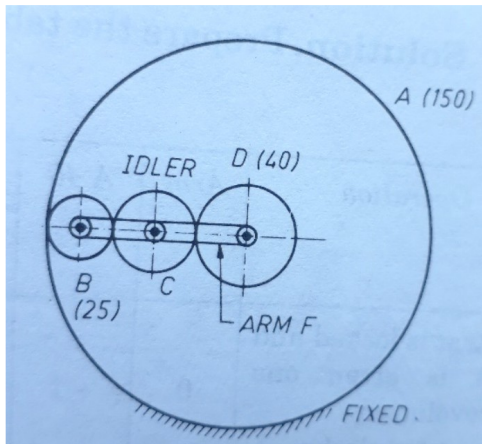

**Fig. 2**

**10 CO3**

**OR**

Two gears in mesh have a module of 10 mm and a pressure angle of 25°. The pinion has 20 teeth and gear has 52. The addendum on both the gears is equal to one module. Determine the  
 (i) number of pairs of teeth in contact  
 (ii) angles of action of the pinion and the wheel

**10 CO3**

Q 9 Four masses A, B, C and D are completely balanced. Masses C and D makes angles of 90° and 195° respectively with that of mass B in the counterclockwise direction. The rotating masses have the following properties:

**20 CO4**

	$m_b = 25 \text{ kg}$ $r_a = 150 \text{ mm}$ $m_c = 40 \text{ kg}$ $r_b = 200 \text{ mm}$ $m_d = 35 \text{ kg}$ $r_c = 100 \text{ mm}$ $r_d = 180 \text{ mm}$ Planes B and C are 250 mm apart. Determine the (i) mass A and its angular position with that of mass B (ii) positions of all the planes relative to plane of mass A		
Q 10	A rear engine automobile is travelling along a curved track of 120 m radius. Each of the four wheels has a moment of inertia of 2.2 kg-m <sup>2</sup> and an effective diameter of 600 mm. The rotating parts of the engine have a moment of inertia of 1.25 kg-m <sup>2</sup> . The gear ratio of the engine to the back wheel is 3.2. The engine axis is parallel to the rear axle and the crankshaft rotates in the same sense as the road wheels. The mass of the vehicle is 2050 kg and the centre of mass is 520 mm above the road level. The width of the track is 1.6 m. What will be the limiting speed of the vehicle if all the four wheels maintain contact with the road surface?	20	CO5
	<b>OR</b>		
	A) How do the effects of gyroscopic couple and of centrifugal force make the rider of a two-wheeler tilt on one side? Derive a relation for the limiting speed of the vehicle.	10	CO5
	B) An aeroplane flying at a speed of 300 kmph takes right turn with a radius of 50 m. the mass of engine and propeller is 500 kg and radius of gyration is 400 mm. if the engine runs at 1800 rpm in clockwise direction when viewed from the tail end, determine the gyroscopic couple and state effect on the aeroplane. What will be the effect if the aeroplane turns to its left instead of right. Also find the effect when engine and propeller moving in the clockwise direction when viewed from the nose end and plane taking i) Left ii) Right	10	CO5